

Clearly the Best

**S 1300**



**ROLL-FAST DOORS**

**EXTERNAL / INTERNAL**



# S 1300

## The Door with quick manual opening for emergency access

**This vertically opening high-speed door really does have it all!**

Over and above the structural features of the S 1100 door type, this vertically opening high-speed door boasts a size range up to 5000mm H x 5000mm W and an even higher opening speed of 1.3 m/sec.

### Full range of equipment inclusive

Compact direct drive with integral gearbox safety device, electronic limit switches, frequency inverter controls with 7-segment display, function-monitoring, closing edge safety device, photocell to monitor the traffic path and brush seals to reduce drafts and ensure a quiet door action.

### Maintenance-friendly

The fold-out sideframes make it quick and easy to carry out maintenance work.

### Emergency opening in a matter of seconds

Thanks to the counterbalance weight, the door can be opened by pull rope

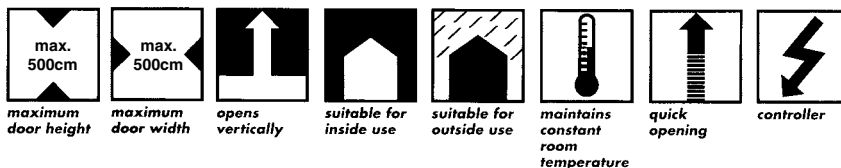

in no time at all. The counter weight (a standard feature) relieves the operator.

### Controls

Various types of opening and closing control systems are available to meet individual operational requirements. Induction loop, radio control, radar, photocell, push-button or pull-switch.

Every door is supplied with a programmable controller.

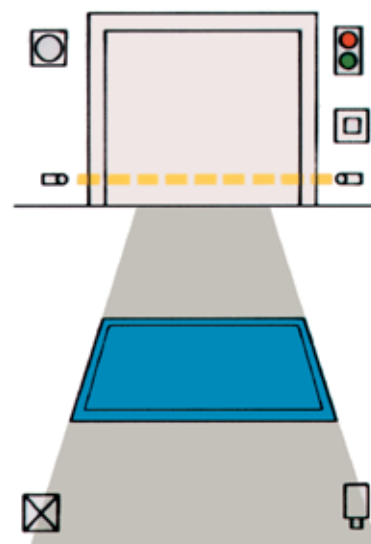

**MELBOURNE**  
55 Northern Road,  
West Heidelberg, Vic. 3081  
Telephone: (03) 9450 1900  
Fax: (03) 9458 3217  
**SYDNEY**  
5 Hallstrom Place,  
Wetherill Park, N.S.W. 2164  
Telephone: (02) 9756 5577  
Fax: (02) 9756 5666

Distributed by:

Blank space for distributor information.

# Clearly the best - SEUSTER Roll-Fast Doors

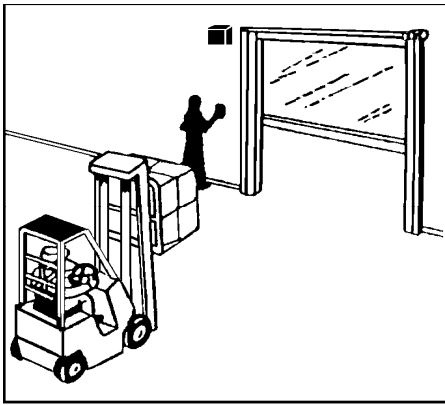

## Push Button:

Least expensive way to control door movement.

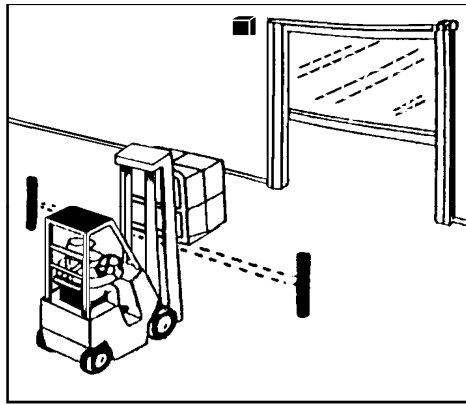

## Photo Electric Cell:

By breaking the beam, the door opens, then closes by time delay.

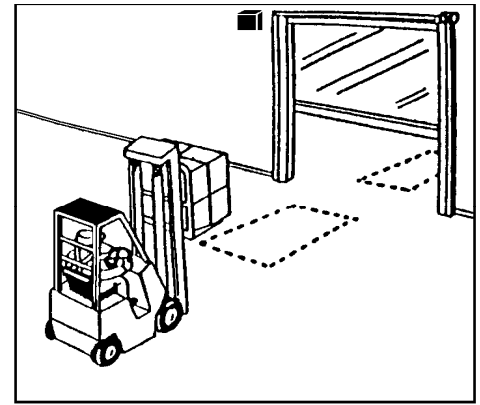

## Induction Loop:

The loop in the floor reacts by magnetic attraction to open the door. Loops can operate for one way or two way traffic. (Specify "one way loop" or "two way loop").

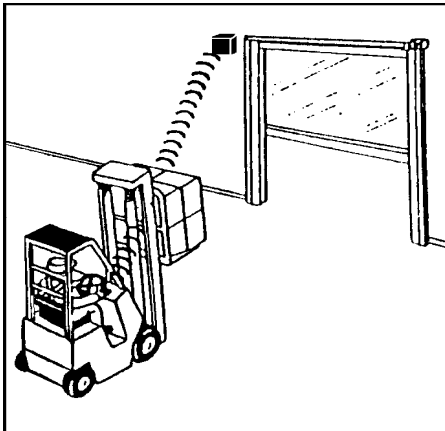

## Remote Control:

A radio transmitter carried by the driver.

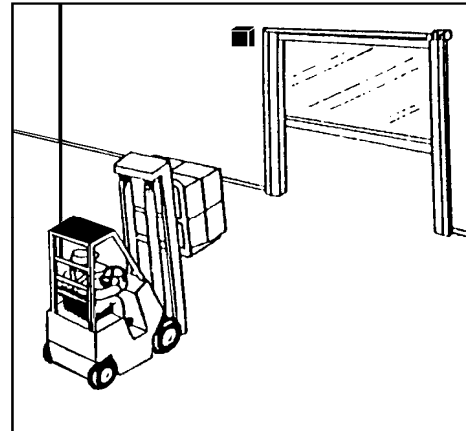

## Pull Switch:

Driver operates pull switch without dismounting. Time delay ensures door closes after use.

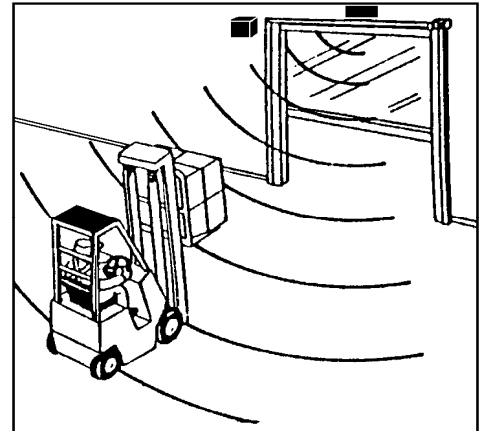

## Motion Detector:

The detector beam detects movement and activates the door.

**M.T.I. Roll-Fast Doors** are automatic rapid opening and closing roller doors with various opening speeds. The door inserts come in either 4mm thick clear PVC panels or 1.5mm thick vinyl panels. On very windy openings the panel can incorporate wind bars.

*Select the control most suited to your needs from the above illustrations.*

**For total environmental control:-**

**Dust, fumes, noise, process separation, temperature control, draught, exclusion of birds and insects.**

For assistance in specifying the requirements for your doors, consult **M.T.I. QUALOS PTY. LTD.**



## MELBOURNE

55 Northern Road,  
West Heidelberg, VIC. 3081  
Telephone: (03) 9540 1900  
Fax: (03) 9458 3217

## SYDNEY

5 Hallstrom Place,  
Wetherill Park, N.S.W. 2164  
Telephone: (02) 9756 5577  
Fax: (02) 9756 5666

## STANDARD FEATURES INCLUDE:

Photo Electric Cell In Door Line.  
Bottom Safety Edge For Auto Reverse.  
Red Safety Vision Strip.  
Running Time Limit Controller.  
Cycle Counter.  
Main Isolator Switch (1).  
Electronic Microprocessor.

## FIRST CHOICE:

In Hospitals,  
Food Factories,  
Milk & Dairy Plants,  
Hotels, Restaurants,  
Chillers, Freezers,  
Cold Storage Complexes,  
All Light & Heavy  
Industry Situations.

## EXTRACTS FROM THE PRODUCT ASSESSMENT REPORT

### ON M.T.I. "SEE-THRU" FLEXIBLE DOORS BY THE DESIGN COUNCIL OF AUSTRALIA 5 NOVEMBER 1982



#### **GENERAL:**

The panel was satisfied that the M.T.I. Qualos "See-Thru" Door, which is made in Australia under the Swiss patent held by Sigerist & Co., qualified for Design Council Selection.

The panel commended the manufacturer on the quality of the construction and the unique design features in supporting the PVC sheeting, allowing it to accommodate movement due to the different co-efficient of expansion between the PVC and the steel door frame, thereby ensuring the PVC panels will stay flat sealing the doorway.

#### **FUNCTION:**

The panel was impressed with the visibility through the PVC door sheeting, even after several years of use. A sample of worn PVC sheet provided evidence of the design criteria and confirmed the safety aspects of the M.T.I. Qualos Pty. Ltd., door.

The self-closing mechanism is concealed in the steel top frame and can be easily adjusted to give a desired closing pressure with maximum resistance to draughts in the closed position.

Another innovative feature is the cam that is connected to the closure. This can be set to hold the door open 90° if required.

The panel considered the provision of steel mounting frames, which are made to measure, a good format. They ensure that the doors are hung in a square and workmanlike manner. The door frame fixing is achieved by bolting through the frame to the opening with approximate size, style and number of connections to suit the building construction.

#### **SAFETY:**

The panel commended the location and design of the hinges, which incorporated a shear-pin in the bottom hinge, designed to give way on impact to protect the door structure. This is susceptible to damage from careless forklift operations and the shear-pin greatly reduces the risks. Replacement of this part is simple and inexpensive and hinge size can be selected depending on the size of the door.

A desirable feature of this shear-pin arrangement is that in the event of an accident the door remains upright on the top hinge, so avoiding injury.

**CONSTRUCTION:**

The unique roll formed steel door frame, which contains the PVC panels, provides a very neat solution to industrial door closures. The all-welded frame and gusset are strong and well finished.

The panel was also impressed with the system of reinforcing the PVC material wherever high stress points occurred.

Stainless steel hinges and galvanised steel frames are provided for food area applications.

**DURABILITY:**

The construction was considered to be virtually maintenance free except for periodic greasing of the closure mechanism and the cleaning of the PVC sheeting.

**VALUE:**

The panel agreed that the prices of M.T.I. Qualos Pty. Ltd., "See-Thru" Doors were competitive and represented good value for money, satisfying a current need for this style of industrial door in a very effective manner.

**AESTHETICS:**

The panel commended the quality of finish and the general appearance of the door particularly the clean lines with absence of surface fixings.

**CONCLUSION:**

The assessment panel recommended that the "See-Thru" Flexible Swing Doors be granted DESIGN COUNCIL SELECTION.